

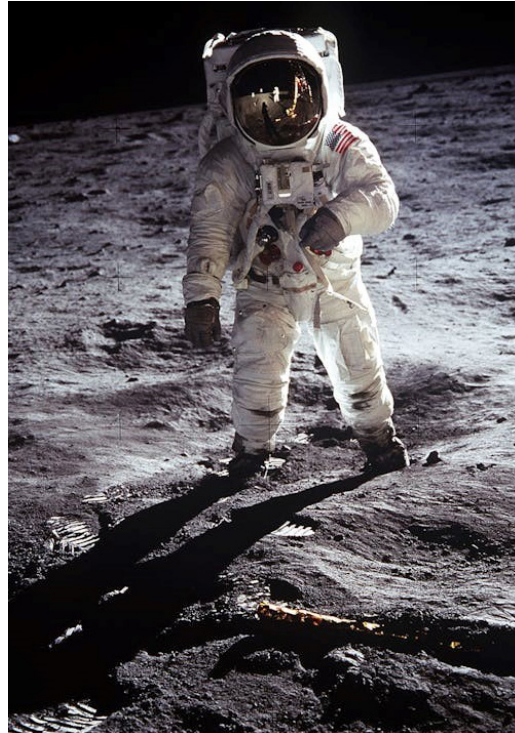

DECEMBER

Activity Sheets

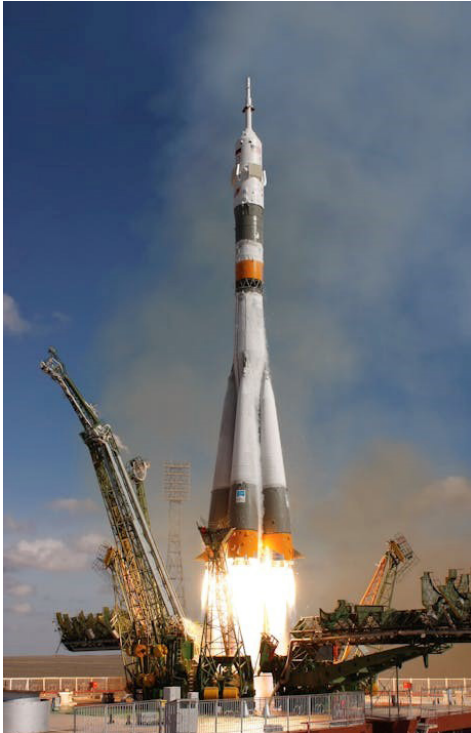

Books about Space

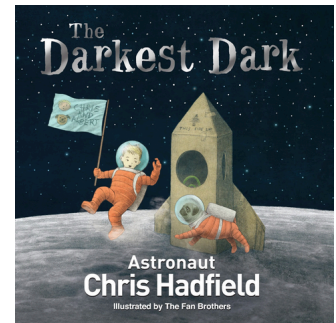
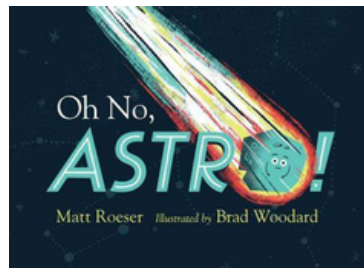
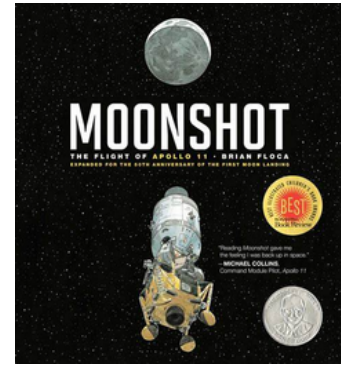
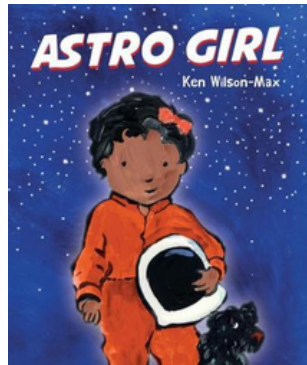
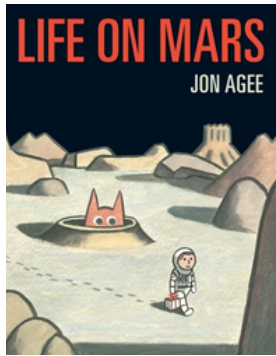

Rhymes, Songs, and Projects

If You're Going to the Moon

Tune: If You're Happy and You Know It

If you're going to the moon, wear your boots

If you're going to the moon, wear your boots

If you're going to the moon.

This is what you have to do,

If you're going to the moon, wear your boots!

Continue singing with other verses like...

Wear your helmet, wear your gloves

Act this song out and then add to the verses by asking children what else they might wear during a visit to outer space/the moon!

Credit: Mel's Desk

melissadepperfamily.net/blog/baby-storytime-moon-and-rockets/



Q-Tip Painting

What you need:

Q-tips cut in half

Construction paper or

Another thicker paper

Tempera Paint or other washable
and safe paint

Try watercolor paints too!

Draw some star outlines on paper or cut a star shape out of paper. Children can decorate or outline their stars with q-tips and paint.

A perfect activity to strengthen fingers and hands for writing. You can also paint a rocket ship, the moon, or something else you might find in outer space.



Song: We're Going to the Moon

Clap your hands as you chant

Zoom, zoom, zoom,

We're going to the moon,

Zoom, zoom, zoom,

We'll be there very soon,

If you'd like to take a trip,

Climb aboard the rocket ship!

Zoom, zoom, zoom,

We're going to the moon,

Zoom, zoom, zoom,

We'll be there very soon!

Ready.....5, 4, 3, 2, 1

BLASTOFF!

Continue singing this song with some other fun verses like...

Fun, Fun, Fun - We're Going to the Sun!

Far, Far, Far - We're Going to the Stars!

MY PLANET

Design your own planet, use different colors and shapes.

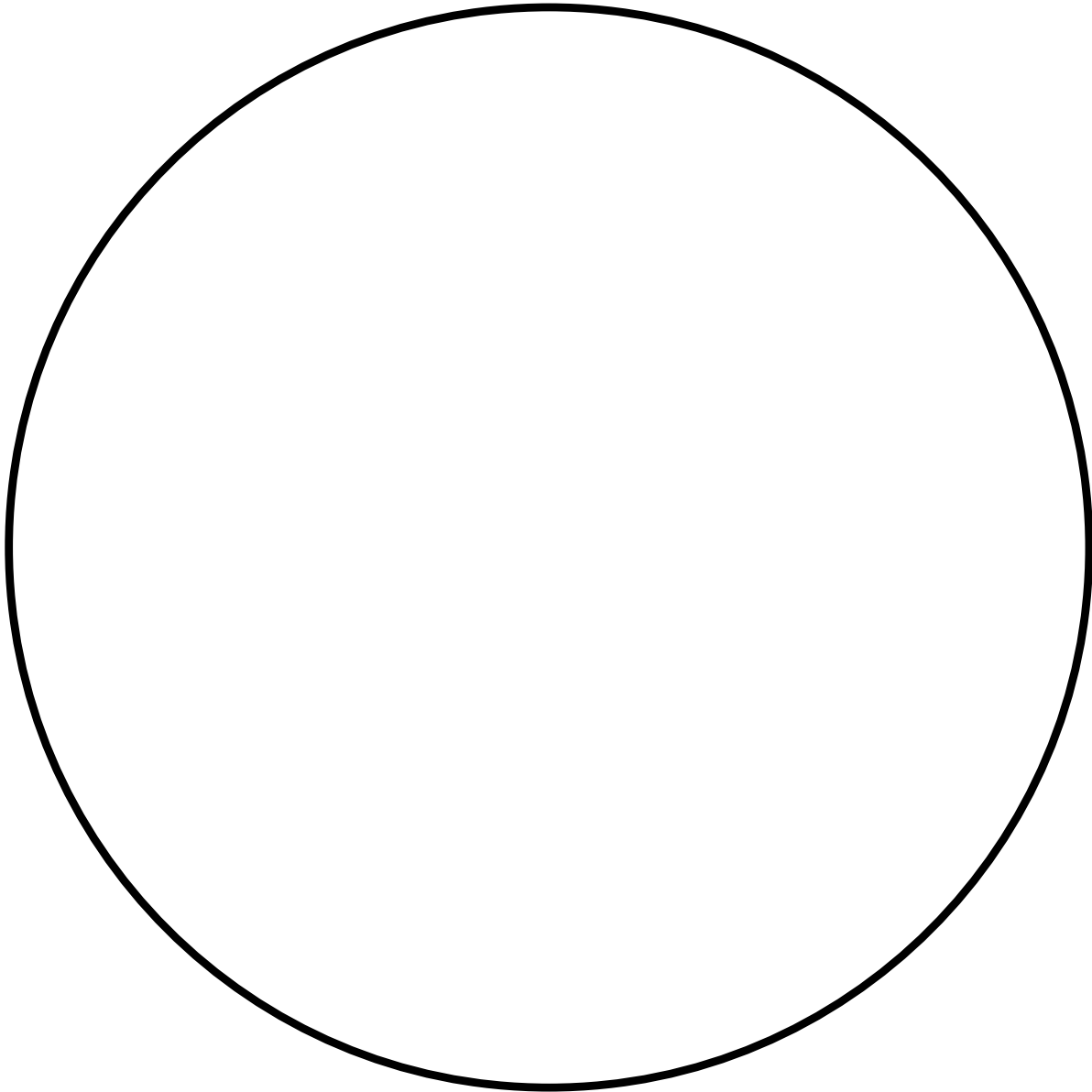

Name of planet: _____



SPACE I SPY



COUNT EACH OBJECT AND WRITE HOW MANY YOU SEE.

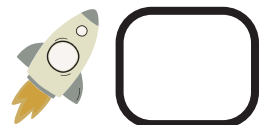

SOLAR SYSTEM

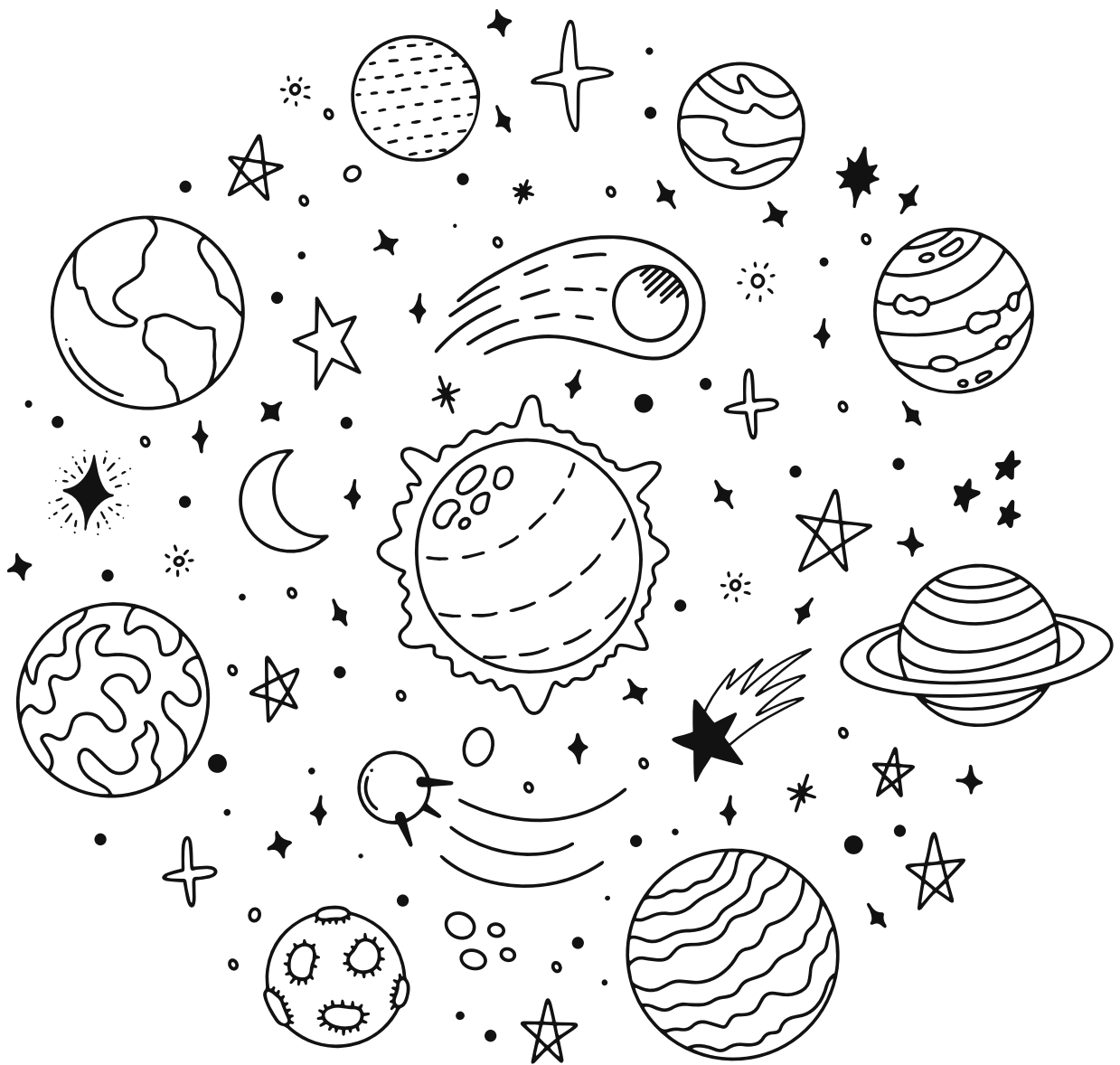

Earth

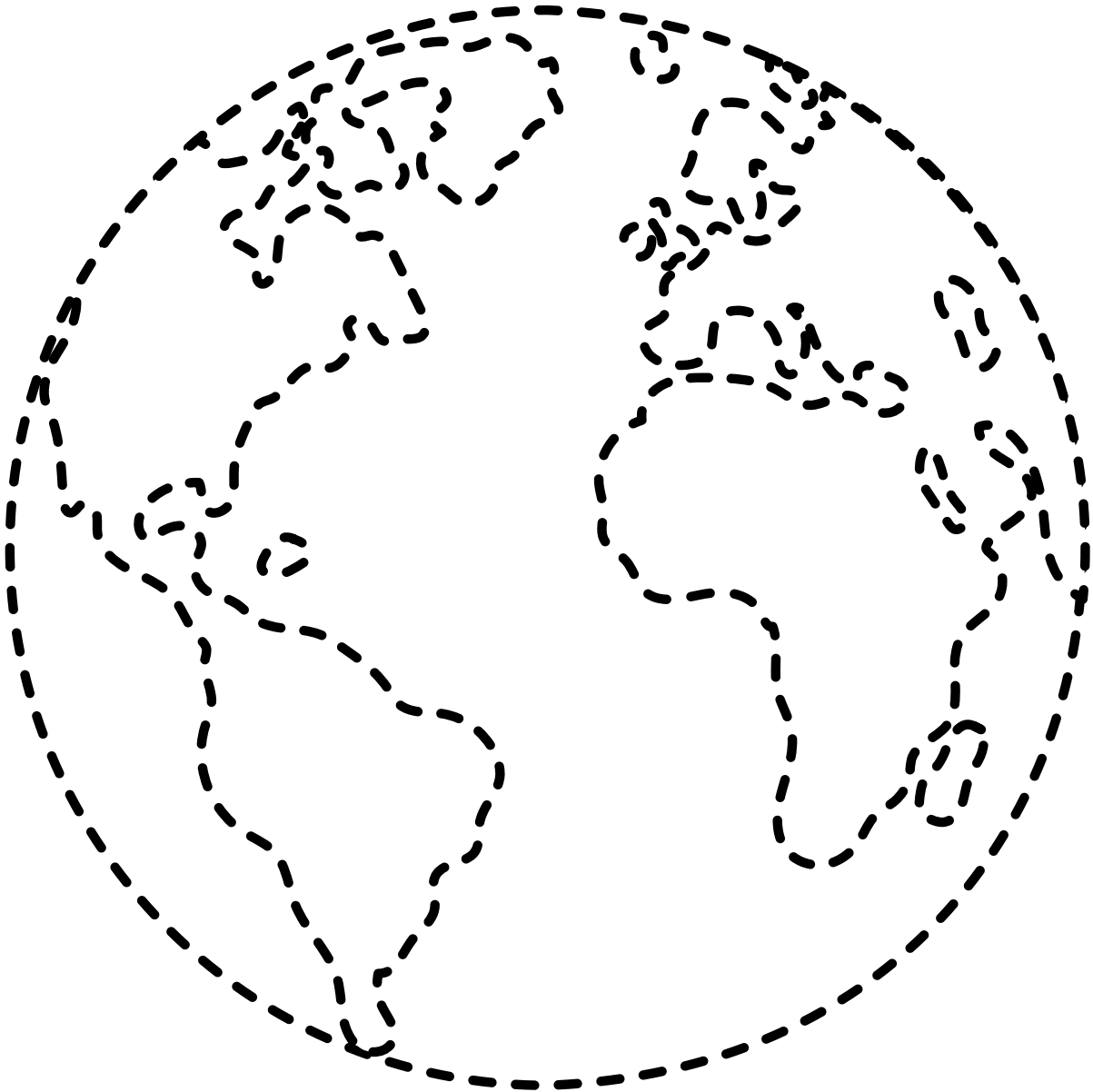

moon

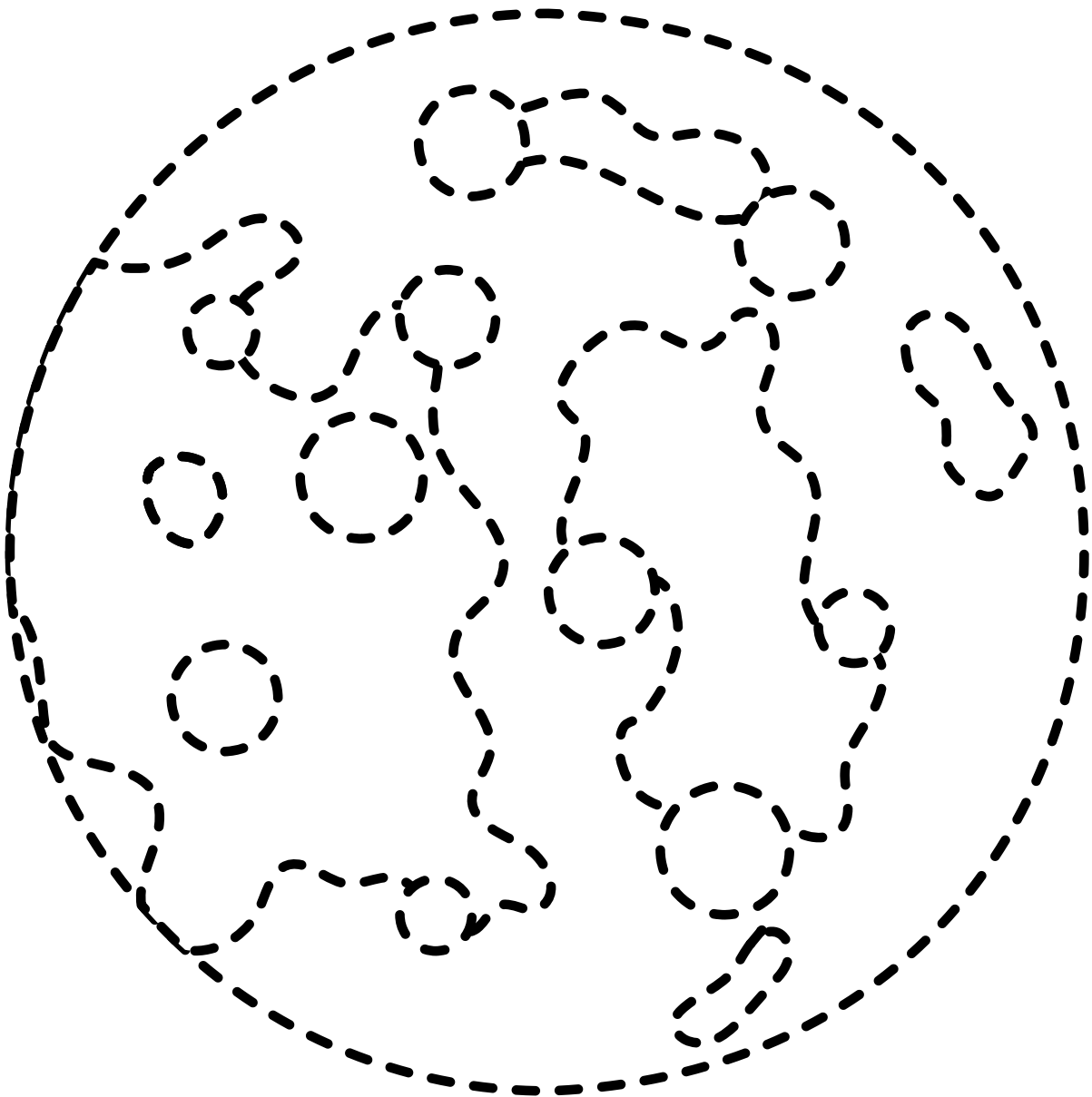

SPACE

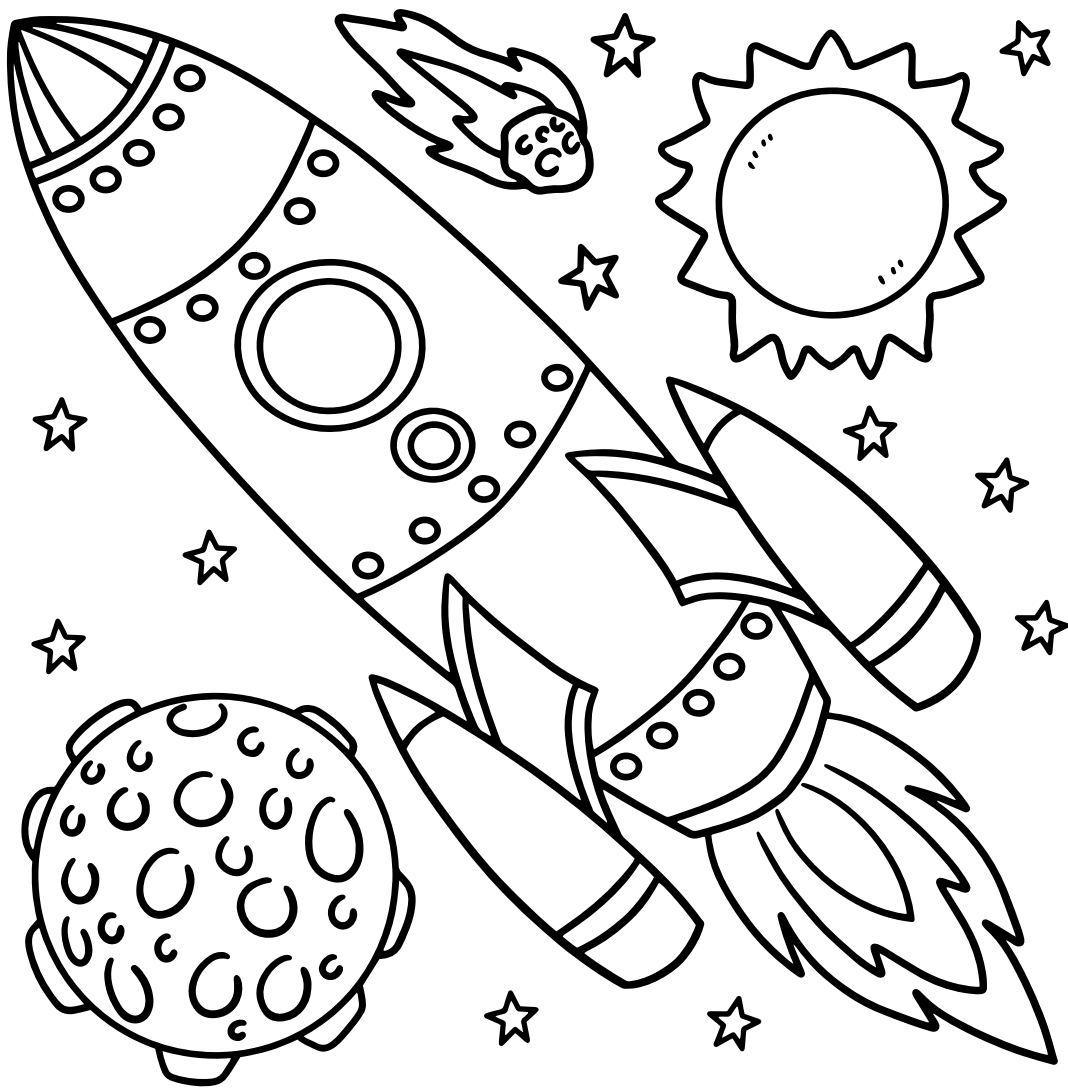

Hidden Objects

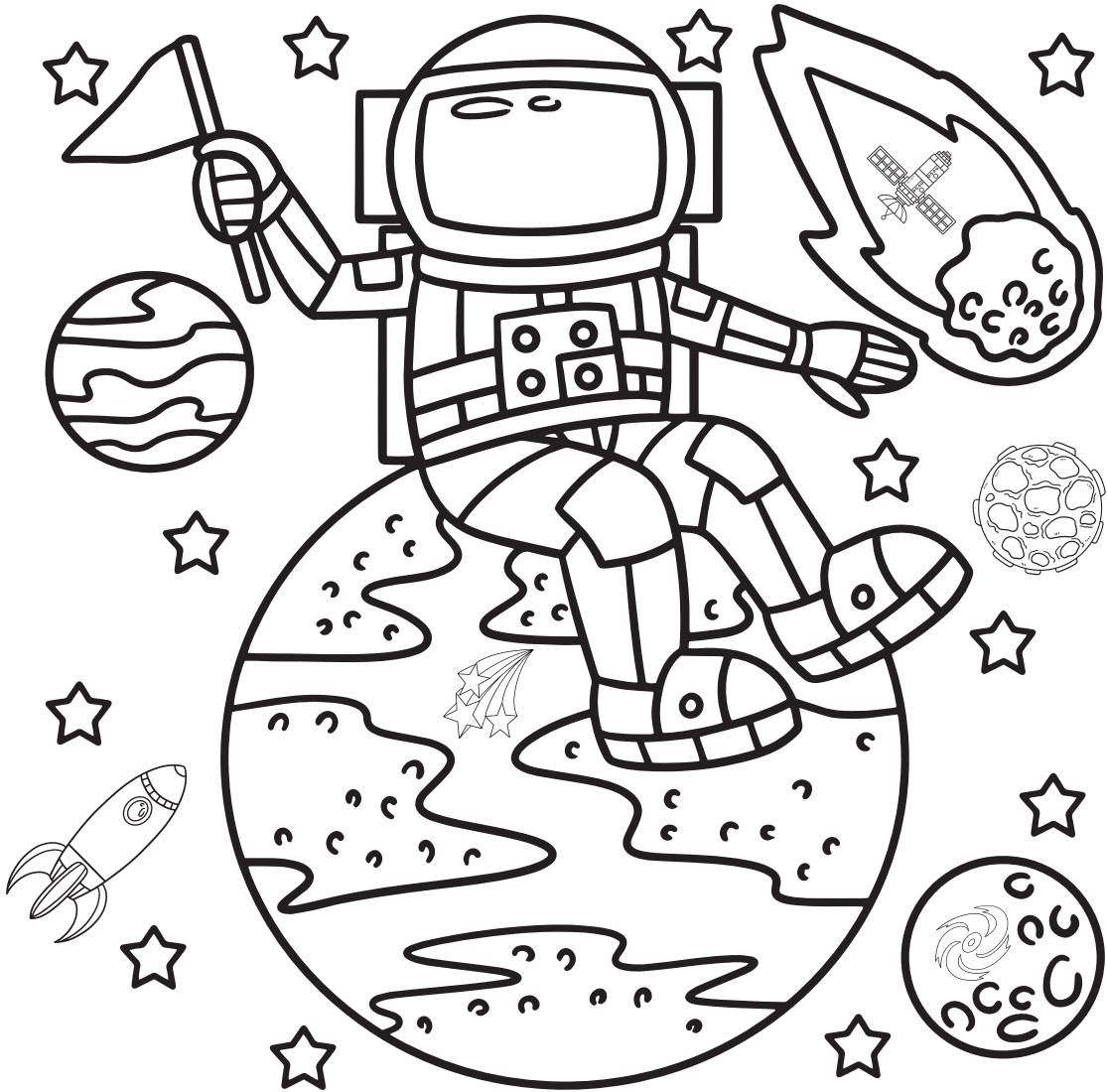

Find the hidden objects below in the picture above.

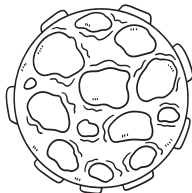
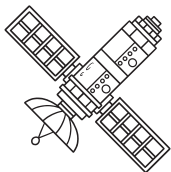
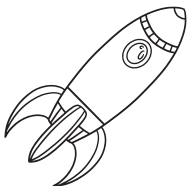

Follow the line



Can you help the astronaut get to the spaceship?

WHAT AM I?

Astronauts use me to get to their destination, what am I? Connect the dots starting with 1 to find out. When finished color me.

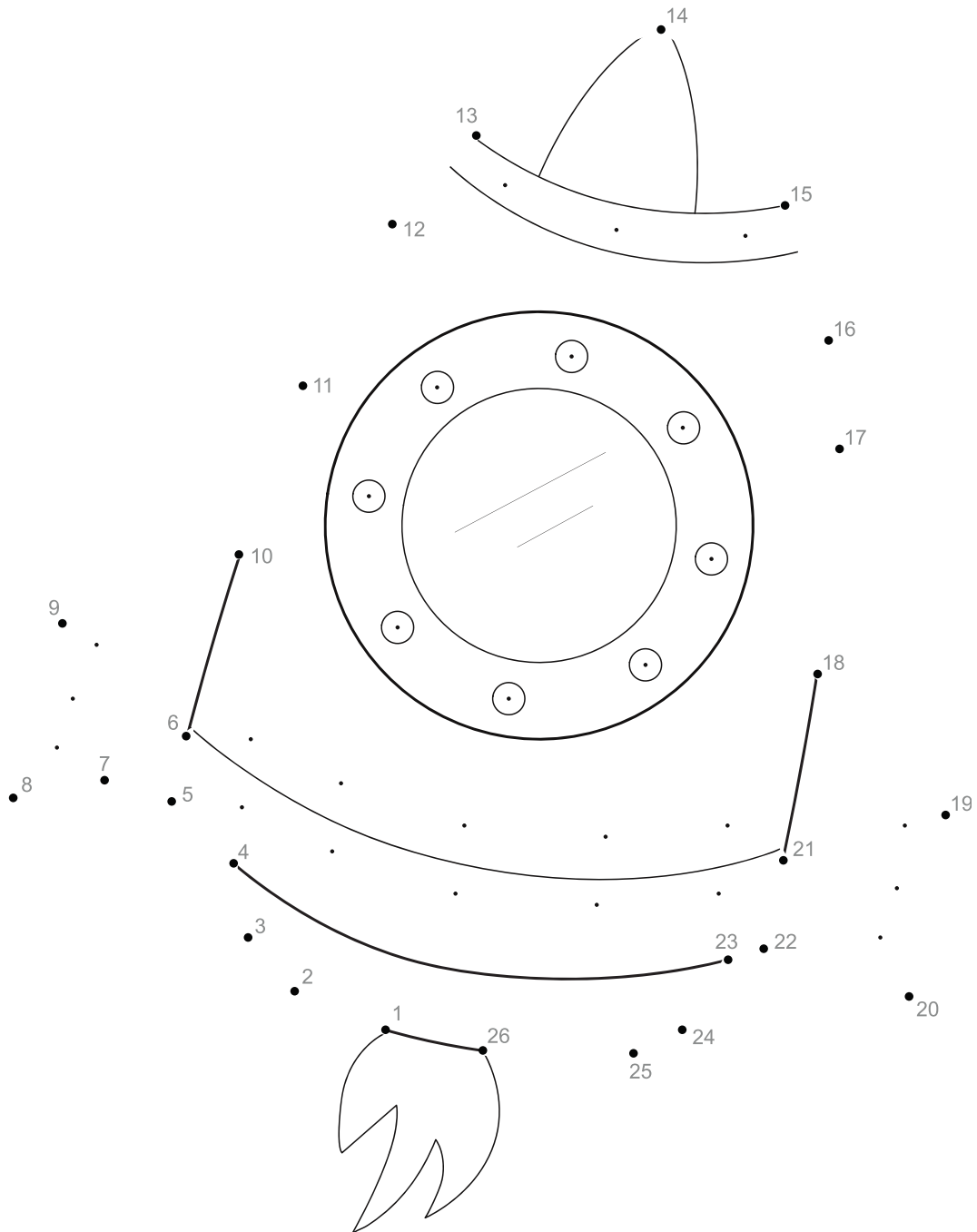
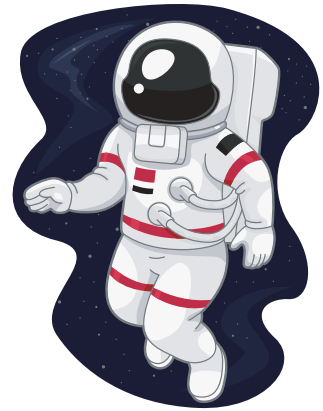

A lot of Stars

Color the stars with 4 points yellow, those with 5 points orange.

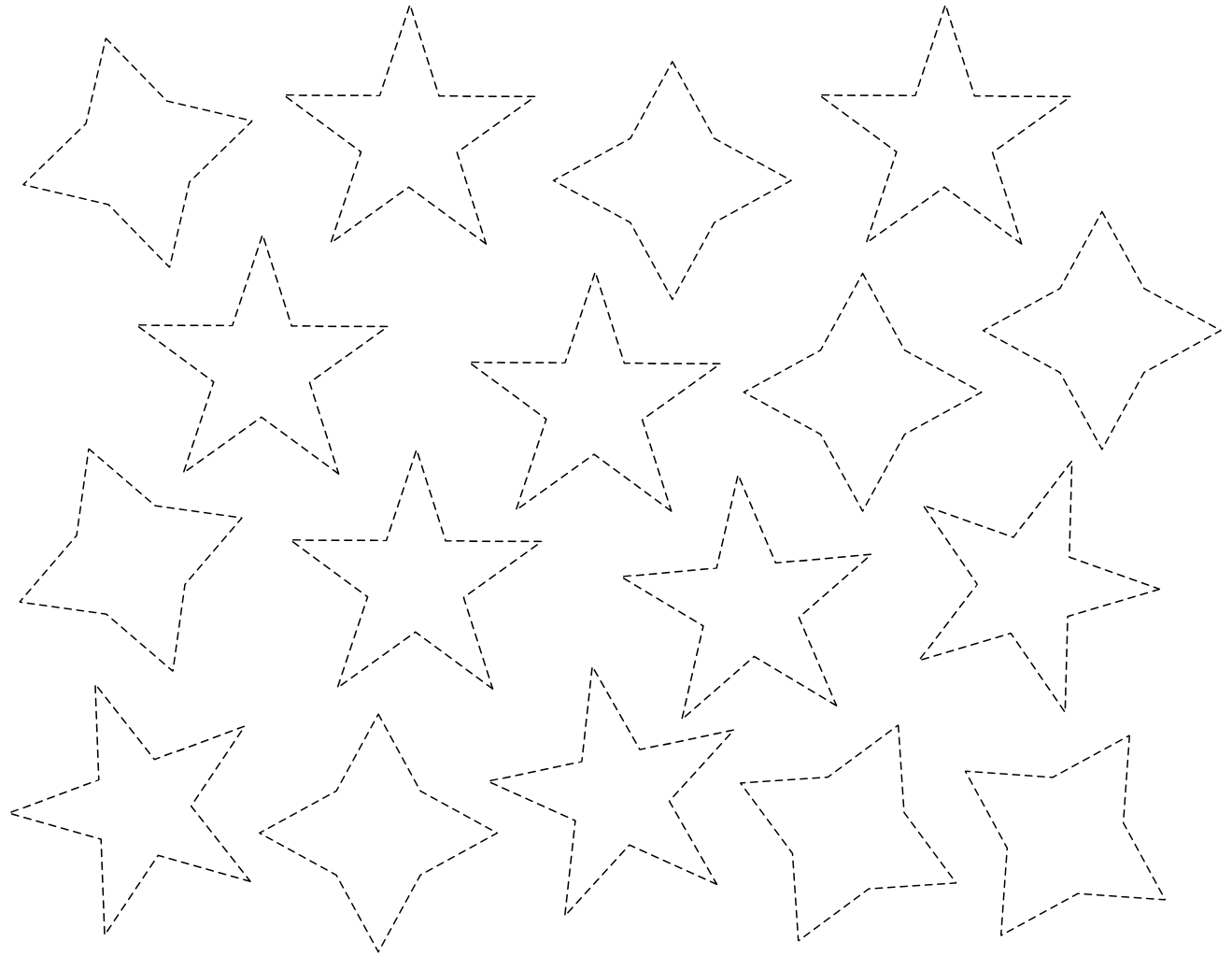

★ TRACING STARS ★

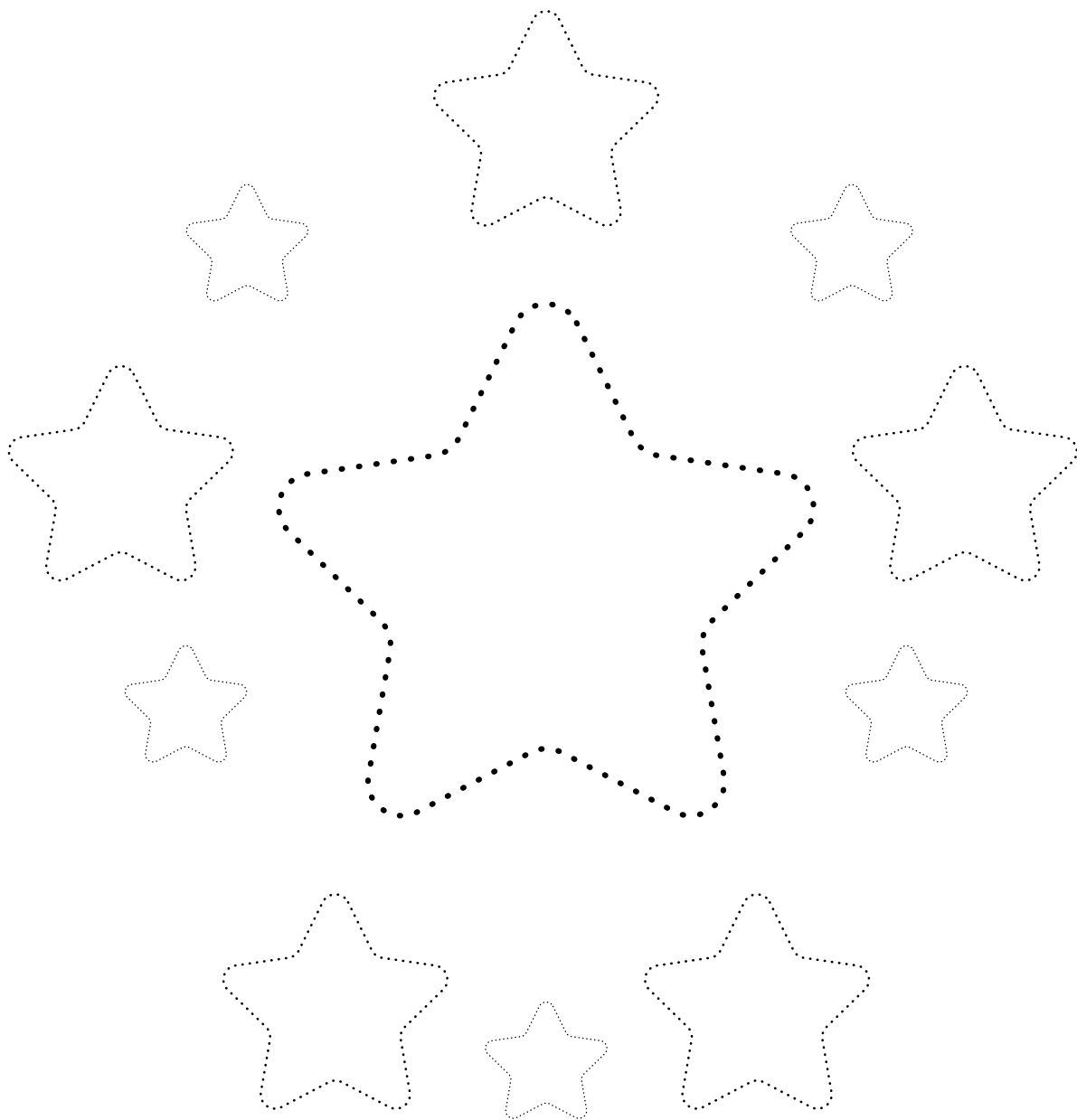

CALM YOURSELF WITH
STAR BREATHING



Trace your finger up one side of the star, while you take a deep breath in. Hold your breath at the point and breathe out as you slide down the other side. Keep going until you've gone around the whole star.

HAPPY NEW YEAR

COLORING

